

THIS DRAWING IS UNPUBLISHED. RELEASED FOR PUBLICATION
 © COPYRIGHT BY TYCO ELECTRONICS CORPORATION. ALL RIGHTS RESERVED.

LOC	DIST	REVISIONS					
GP	00	P	LTR	DESCRIPTION	DATE	DWN	APVD
		S		REVISED PER ECO-08-005709	18FEB08	JDP	CWR

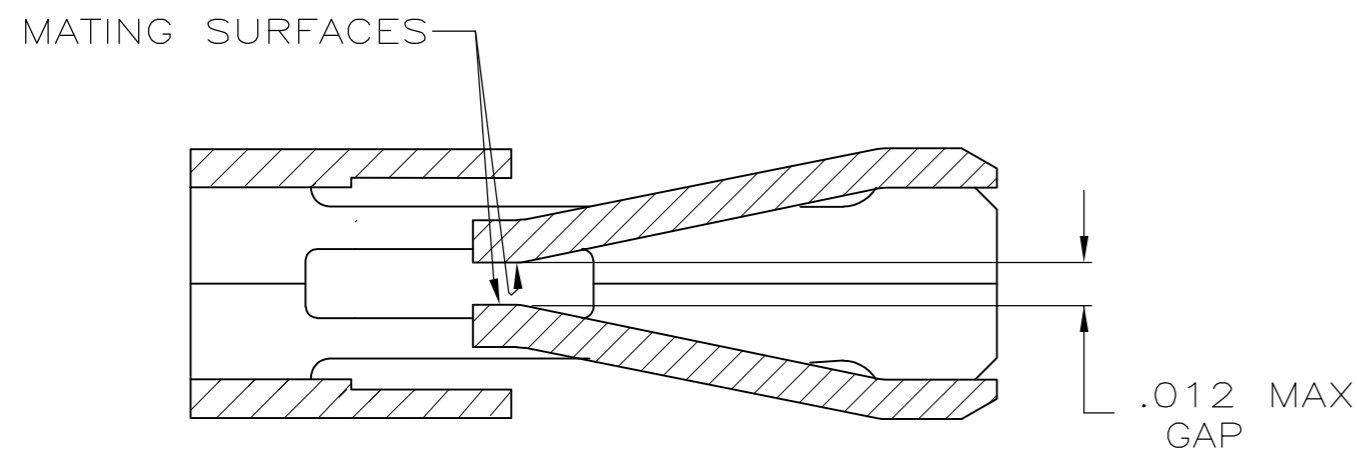

SECTION B-B
SCALE 20:1

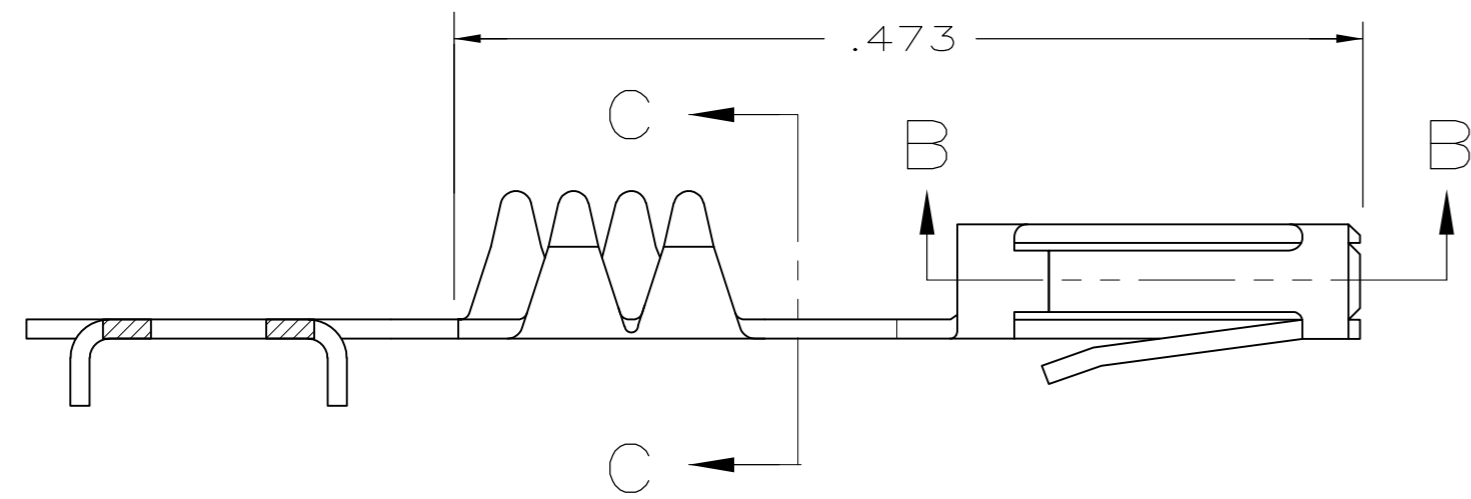
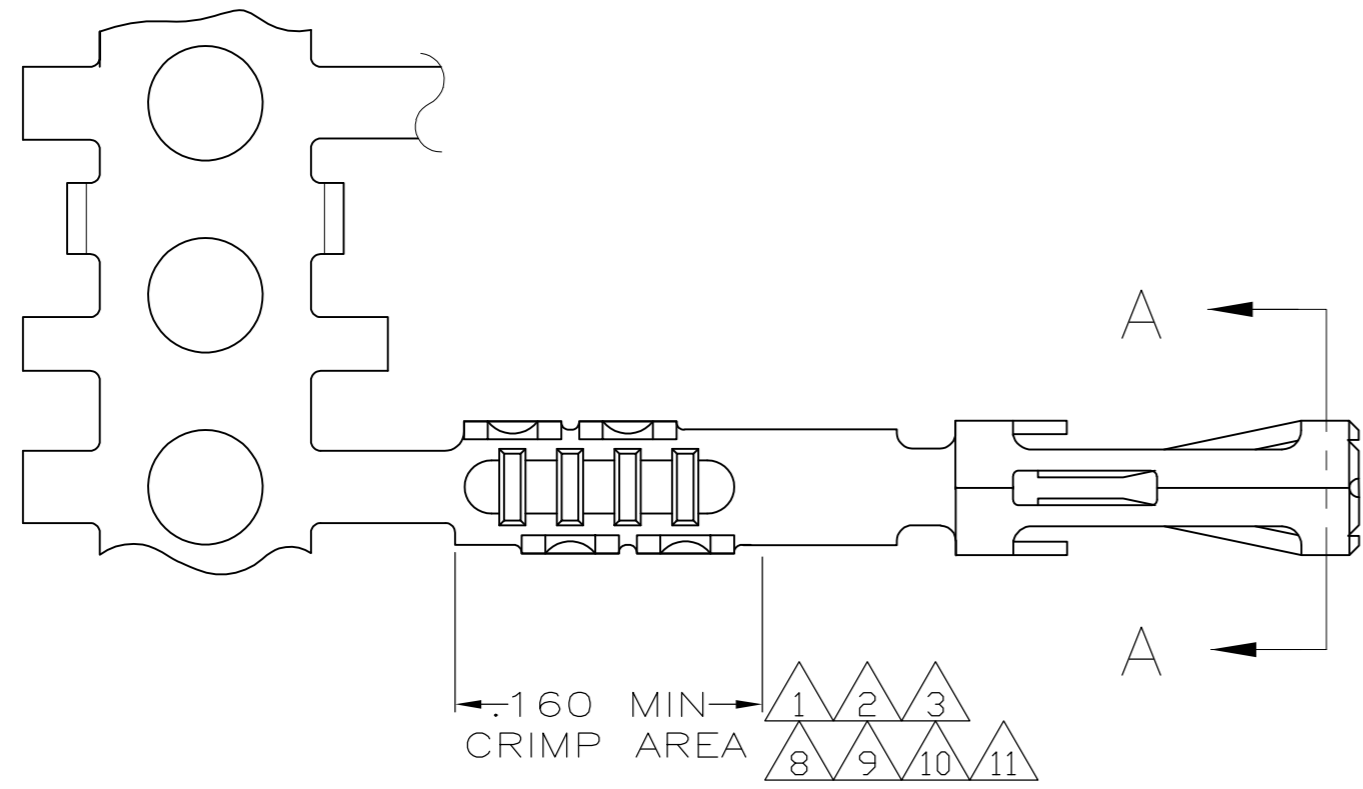
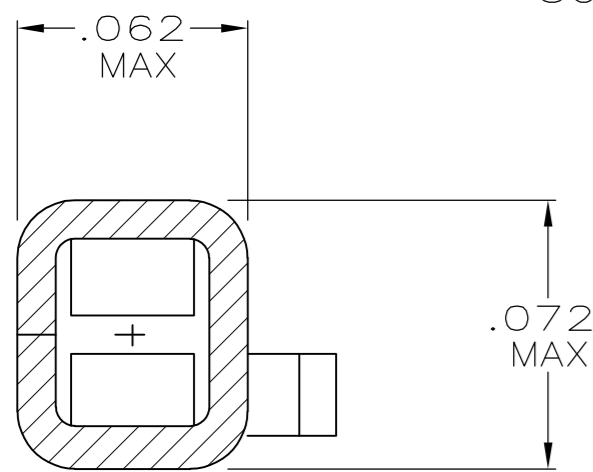

SECTION A-A
SCALE 20:1

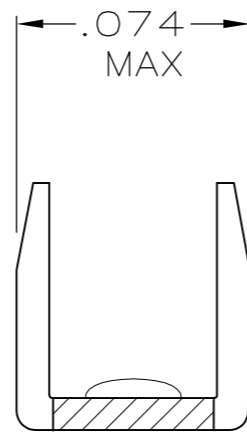

SECTION C-C
SCALE 20:1

- 1 PREPLATED WITH NICKEL UNDERPLATE .000050 THK ON ENTIRE CONTACT WITH GOLD .000015 THK ON MATING AREA AND PLATED WITH BRIGHT TIN-LEAD .000100 THK IN CRIMP AREA
- 2 PREPLATED WITH NICKEL UNDERPLATE .000050 THK ON ENTIRE CONTACT WITH GOLD .000030 THK ON MATING AREA AND PLATED WITH BRIGHT TIN-LEAD .000100 THK IN CRIMP AREA
- 3 PREPLATED WITH NICKEL UNDERPLATE .000050 THK ON ENTIRE CONTACT WITH GOLD .000050 THK ON MATING AREA AND PLATED WITH BRIGHT TIN-LEAD .000100 THK IN CRIMP AREA
- 4 .000100 BRIGHT TIN-LEAD OVER .000050 PRE-PLATED NICKEL UNDERPLATE ON ENTIRE CONTACT.
- 5. MATING POST LENGTH ACCEPTED:
SINGLE ROW HOUSINGS .220-.323
DOUBLE ROW HOUSINGS .235-.323
- 6 PREPLATED WITH NICKEL UNDERPLATE .000050 THK ON ENTIRE CONTACT WITH GOLD .000050 THK ON MATING AREA AND GOLD FLASH OVER ENTIRE CONTACT.
- 7 PREPLATED WITH NICKEL UNDERPLATE .000050 THK ON ENTIRE CONTACT WITH GOLD .000030 THK ON MATING AREA AND PLATED WITH GOLD .000030 THK ON ENTIRE CONTACT EXCEPT .000003 MIN THK PERMISSIBLE ON INTERIOR OF CONTACT BOX EXCLUSIVE OF MATING AREA.
- 8 PREPLATED WITH NICKEL UNDERPLATE .000050 MIN THK ON ENTIRE CONTACT WITH GOLD .000015 MIN THK ON MATING AREA AND PLATED WITH GOLD FLASH IN CRIMP AREA.
- 9 PREPLATED WITH NICKEL UNDERPLATE .000050 MIN THK ON ENTIRE CONTACT WITH GOLD .000030 MIN THK ON MATING AREA AND PLATED WITH GOLD FLASH IN CRIMP AREA.
- 10 PRE-PLATED WITH NICKEL UNDERPLATE .000050 THICK ON ENTIRE CONTACT WITH GOLD FLASH IN CRIMP AREA AND .000100 MIN TIN ON MATING AREA.
- 11 PRE-PLATED WITH NICKEL UNDERPLATE .000050 THICK ON ENTIRE CONTACT WITH GOLD .000050 THICK ON MATING AREA AND PLATED WITH GOLD FLASH IN CRIMP AREA.

SUPSD BY 487406-2

11	2-487406-6
10	2-487406-4
9	2-487406-3
8	2-487406-2
7	1-487406-0
6	487406-9
4	487406-4
3	487406-3
2	487406-2
1	487406-1
FINISH	PART NUMBER

THIS DRAWING IS A CONTROLLED DOCUMENT.		DWN 11-10-84 D.DOLLYHIGH	Tyco Electronics Corporation Harrisburg, PA 17105-3608	
DIMENSIONS: INCHES		CHK 11-10-84 J.COMPTON	RECEPTACLE CONTACT, STANDARD PRESSURE	
TOLERANCES UNLESS OTHERWISE SPECIFIED:		APVD -	NAME	
0 PLC ± -		PRODUCT SPEC	108-9024	
1 PLC ± -		APPLICATION SPEC	114-16015	
2 PLC ± -		WEIGHT	-	
3 PLC ± .005		SIZE	A2	
4 PLC ± -		CAGE CODE	00779	
ANGLES ± -		DRAWING NO	C=487406	
FINISH		RESTRICTED TO	-	
SEE TABLE		SCALE	10:1	
MATERIAL: PHOSPHOR BRONZE		SHEET	1 of 1	
CUSTOMER DRAWING		REV	S	